

Lybra LG

Continuous weight-loss gravimetric units for Masterbatch and Additive dosing

Benefits:

- Control and management of masterbatch consumption.
- Elimination of dosing variations: high level of accuracy and repeatability.
- Wide range of capacities.
- Straightforward user interface with 7" touch screen.
- Data logger for consumption totalizers.
- Connection to remote production management systems.

Main features:

- Proprietary loss-in-weight control.
- Angled auger assembly.
- Central block with smooth internal surfaces.
- Brush-less motor with integrated control and closed loop rotation feature.
- Dual load-cell for masterbatch hopper only.
- 2 configurations: 1 station (LG1) or 2 stations (LG2).
- Dedicated masterbatch loader support bracket.

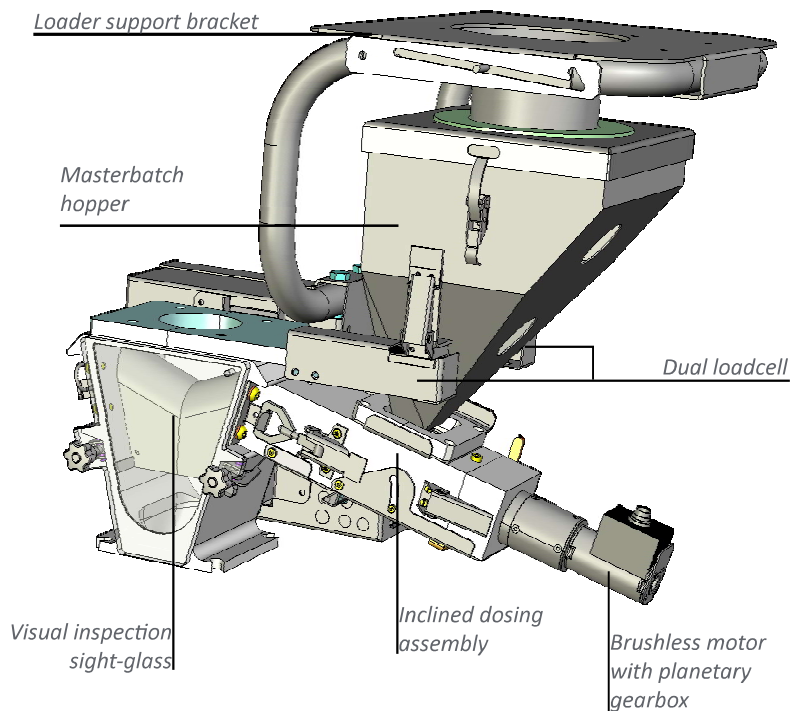

The unit can accommodate up to two independent dosing stations, which can even be of different capacities and be retrofitted to meet changing production needs. Each dosing station can be configured for individual capacities in the tens of g/h, up to **170 kg/h**. Each dosing station is equipped with a **proprietary loss-in-weight control** to measure the amount of material fed by the dosing screw into the unit's static mixer.

The unit comprises a **microprocessor control system with 7 inch touch screen**. A single screen, with intuitive graphical interfaces, allows the operator to control operation of the whole system, compare preset dosing values with actual values, check instantaneous production values and access all the unit's functions. Connection to external supervision systems (by means of an Ethernet) means settings can be downloaded and exported, while it also provides the option of **controlling the unit remotely**.

Wf Winfactory 4.0
4.0 R E A D Y

The dosing auger is available in **3 configurations**: single, dual or **triple helical shaft** for controlling material dosing in low percentages with a high level of accuracy and repeatability.

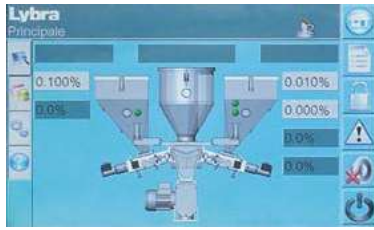
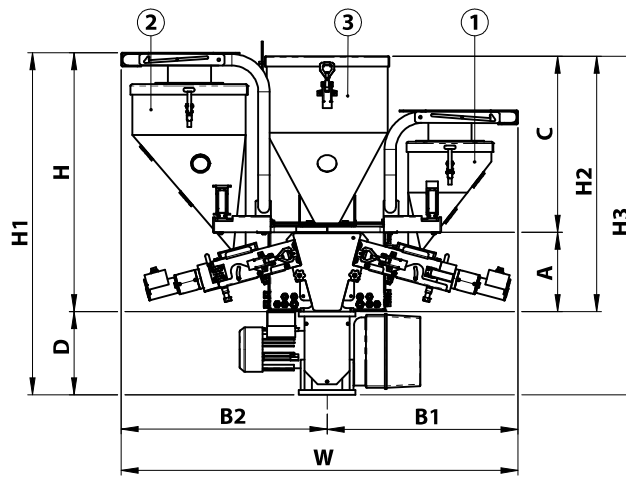

7" touch screen type HMI

AUGERS THROUGHPUT*						
n.	Diam. x Pitch mm	Config.	R=28,125:1	R=50:1	R=28,125:1	R=50:1
			kg/h		g/s	
51	8x8	Single	0,48-3,67	0,21-2,04	0,11-1,02	0,05-0,56
52	10x12	Dual	0,90-8,86	0,48-4,93	0,25-2,46	0,13-1,36
53	16x8	Triple	1,84-17,80	1,00-10,00	0,51-4,94	0,27-2,70
56	20x15	Triple	4,65-43,50	2,50-24,23	1,29-12,08	0,69-6,73
58	25x30	Single	7,20-69,91	3,87-38,94	2,00-19,42	1,08-10,81
59	34x30	Single	12,24-118,29	6,50-65,90	3,40-32,86	1,80-18,30
61	39x50	Single	19,69-191,35	10,60-106,60	5,47-53,15	2,94-29,60

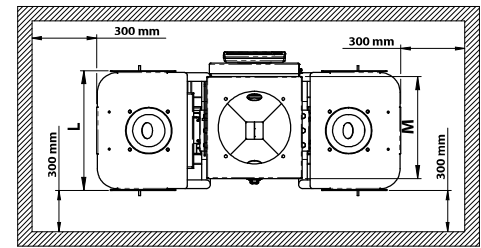

Machine shown in its complete configuration

*continuous mode, material bulk density 0,691 kg/dm³

CHARACTERISTICS			STATION (1-2)			
Maximum number of materials	-	3				
Dosing stations 1-2 hopper ø185 capacity	dm3	07-12	Hopper capacity (l)	7	12	20
Dosing station 1-2 hopper ø280 capacity	dm3	12-20	A (mm)	210	210	210
Mixing chamber capacity (optional)	dm3	1	B1/B2 (mm)	505	545	606
Maximum number of auger stations	-	2	D (mm)	220	220	220
Mixer motor power	kW	0.18 (230/50)	H (mm)	533	685	685
		0.22 (220/60)	H1 (mm)	753	905	905
Auger station motor power	kW	0.065 (230/50)	L (mm)	413	413	413
		0.08 (220/60)	W (mm)	B1 + B2		
Maximum noise level	db(A)	<80				

CENTRAL HOPPER (3)											
	TC3	TC20	TB5	TB10	TB20	TB40	T2M	T3M	T5M	T10M	T20M
A (mm)	210	210	210	210	210	210	210	210	210	210	210
C (mm)	278	466	293	435	565	782	231	323	368	434	574
D (mm)	220	220	220	220	220	220	220	220	220	220	220
H2 (mm)	488	686	503	645	775	1002	441	533	578	644	784
H3 (mm)	708	896	723	865	995	1222	661	753	798	864	1004
M (mm)	ø238	353	ø309	ø309	ø309	ø309	ø193	ø300	ø300	ø373	ø373