

30 Series

GRANULATORS

Model; UDS30-50 (12x20)

The UDS30-50 granulator is an ideal general purpose granulator for beside-the-machine processing of injection, blow molding, and extrusion scrap. This compact, quiet, energy efficient granulator produces high quality regrind due to low rotor speed, and high angle cutting action. The UDS30-50 is fully soundproofed granulator featuring a tangential feed cutting chamber, 3 blade open rotor with scooped rotor design and throughput rates from 440 to 660 lbs/hr (200 to 300 kg/hr).



UDS30-50

Standard Specifications & Features:

- 11 KW (15HP) 4P Motor-450 RPM Rotor Speed
- Full Integral Soundproofing
- 3 blade open rotor with solid flywheel drive pulley
- Belt Drive with Solid Flywheel Rotor Pulley
- Suitable for Manual or Conveyor Feeding
- Front Removable Screen Cradle
- Reversible Screen
- Highest Safety Standards with Interlocked Safety Switches, Disconnect, E-Stop
- Regrind Collection Bin designed for Auger and Vacuum Loader
- Quick Opening and Easy Cleaning
- 460/3/60 Volts

Configuration Options:

- Adjustable Rotating Knives, with Knife Gap Adjustment Fixture
- Motor 15 KW (20HP) 4 Pole; 450 RPM Rotor Speed
- Additional Rear Entry Hopper, Sound Proofed, for Long, Wide and Relatively Flat Feedstock, 150 mm High x 500 mm Wide Opening
- Additional Side Entry Hopper, Sound Proofed, for Long Pipe/Profile Type Feedstock, 150mm square Opening
- Larger Feed Opening, for Feeding Longer Parts
- Wear Resistant Cutting Chamber, NIPLOY Treatment
- Tilting Tray for Feed Opening

Accessories:

- Pneumatic Evacuation System, machine mounted with sound enclosure, choice of 2 HP (1.55 kW) or 3 HP (2.2 kW), machine mounted Cyclone with Top Mount Filter
- Cyclone Support Stand for Gaylord Discharge
- Side Mount Filter for Cyclone
- Sound Enclosure for Cyclone
- Side Discharge Auger \varnothing 55xL3000 mm, without Auger Support





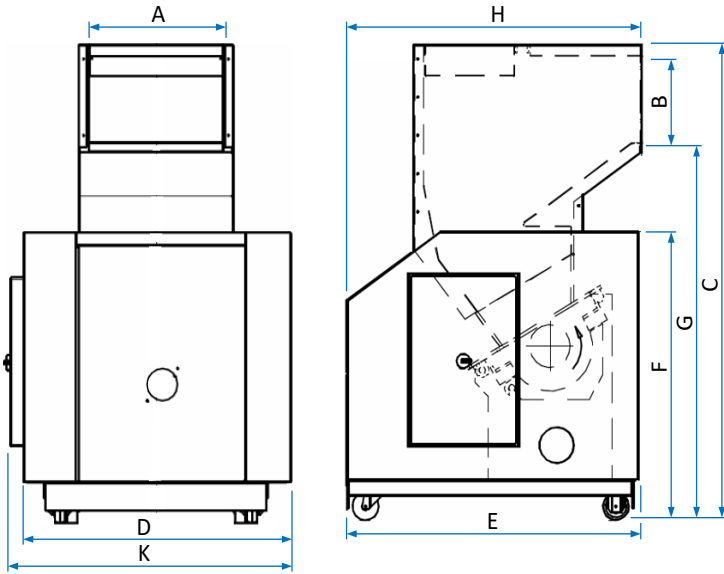

Safety:

- CE Certified
- An Electric Board Constantly Controls all Security Switches and Wiring
- In Case of any Malfunctioning it Stops the Granulator and Displays the Failed Component.

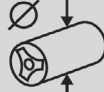

w/ Optional Machine Mounted Pneumatic Evacuation System

Dimensions and Specifications:										
		A	B	C	D	E	F	G	H	K
UDS30-50	in	20.1	12.2	67.0	40.1	43.4	40.7	53.1	44.0	42.1
	mm	510	310	1702	1019	1102	1034	1350	1118	1069

Dimensions and Specifications:								
								
	Feed Opening in / mm	Number of Rotating Blades	Number of Stationary Blades	Rotor Dia. in / mm	Rotor Speed RPM	Motor HP / KW Std. (Optional)	Screen Hole Dia. in / mm	Avg. Throughput lbs/hr / (kg/hr)*
UDS30-50	12 x 20	3	2	12.0	450	15 (20)	5/16 (1/4, 3/8)	550 - 748
	305 x 510			305		11 (15)	8 (6, 10)	250 - 340

Most Efficient Cutting:

- High Angle Approach Between Rotating and Stationary Blades for More Efficient Cutting Action, Less Heat Generation, and High Quality Regrind
- Feed Hopper Design and Scooped Rotor Design for a More Positive Ingestion of Bulky Parts
- Massive Solid Flywheel Provides Additional Inertia
- Heavy Duty Screen Cradle Support Allows for Thinner Screen Making it Easier for Regrind to Pass Through

Adjustable Rotary Knives (Optional):

- Allows for Constant Cutting Circle - Maintains Optimal Distance Between Rotor Knives and Screen After the Knives have been Sharpened
- Allows for Smallest Knife Gap Possible for Highest Quality Regrind, Reduced Power Consumption, Reduced Heat Generation and Highest Throughput
- Allows for Longer Knife Life by Allowing for the Minimal Amount of Material to be Taken from Each Knife when Re-sharpening. Knives do Not have to be Sharpened as a Set as Each Knife is Gapped Independently of the other
- Knife Gap Adjustment Fixture for Easy and Accurate Knife Gap Adjustment Outside of the Unit

* Average throughput depends on part size and shape, material type, method of feeding, method of regrind evacuation, screen size.