

# Lybra LV

## Volumetric units for Masterbatch and Additive dosing

### Benefits

- Elimination of dosing variations: high level of accuracy and repeatability.
- Wide range of capacities.
- Straightforward user interface with 7" touch screen.
- Connection to remote production management systems.

### Main features

- Angled auger assembly.
- Central block with smooth internal surfaces.
- Brush-less motor with integrated control and closed loop rotation feature.
- 2 configurations: 1 station (LV1) or 2 stations (LV2).
- Optional integrated mixer unit.
- Optional specific regrind station 40 dm<sup>3</sup>.



The unit can accommodate up to two independent dosing stations, which can even be of different capacities and be retrofitted to meet changing production needs. Each dosing station can be configured for individual capacities in the tens of g/h, up to 170 kg/h.

The unit comprises a microprocessor control system with 7 inch touch screen. A single screen, with intuitive

graphical interfaces, allows the operator to control operation of the whole system, compare preset dosing values with actual values, check instantaneous production values and access all the unit's functions. Connection to external supervision systems (by means of an Ethernet) means settings can be downloaded and exported, while it also provides the option of controlling the unit remotely.

**Wf** Winfactory 4.0  
4.0 R E A D Y

# Piovan

Customers. The core of our innovation

[www.piovan.com](http://www.piovan.com)

The dosing auger is available in **3 configurations: single, dual or triple helical shaft** for controlling material dosing in low percentages with a high level of accuracy and repeatability.

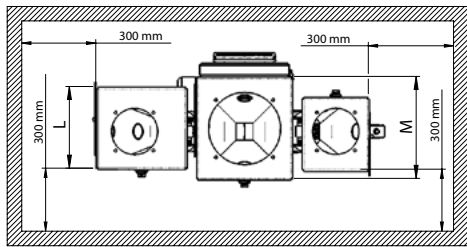

Machine shown in its complete configuration

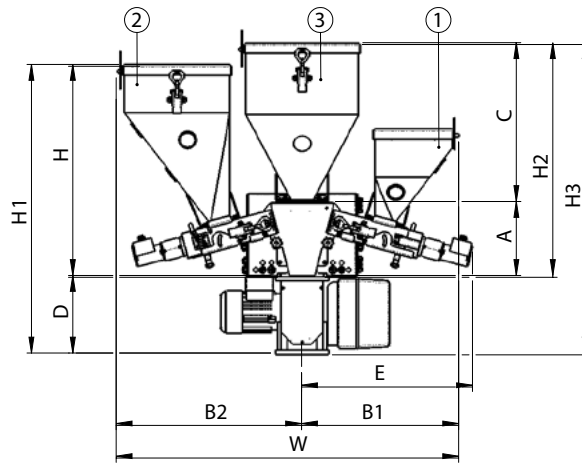

AUGERS THROUGHPUT*						
n.	Diam. x Pitch mm	Config.	R=28,125:1	R=50:1	R=28,125:1	R=50:1
			kg/h		g/s	
51	8x8	Single	0,48-3,67	0,21-2,04	0,11-1,02	0,05-0,56
52	10x12	Dual	0,90-8,86	0,48-4,93	0,25-2,46	0,13-1,36
53	16x8	Triple	1,84-17,80	1,00-10,00	0,51-4,94	0,27-2,70
56	20x15	Triple	4,65-43,50	2,50-24,23	1,29-12,08	0,69-6,73
58	25x30	Single	7,20-69,91	3,87-38,94	2,00-19,42	1,08-10,81
59	34x30	Single	12,24-118,29	6,50-65,90	3,40-32,86	1,80-18,30
61	39x50	Single	19,69-191,35	10,60-106,60	5,47-53,15	2,94-29,60

\*continuous mode, material bulk density 0,691 kg/dm<sup>3</sup>

CHARACTERISTICS			STATION (1-2)		
Maximum number of materials	-	3	Hopper capacity (l)		
Dosing stations 1-2 hopper ø185 capacity	dm3	07-12	7	12	20
Dosing station 1-2 hopper ø280 capacity	dm3	20	A (mm)	210	210
Mixing chamber capacity (optional)	dm3	1	B1/B2 (mm)	446	526
Maximum number of auger stations	-	2	D (mm)	220	220
Mixer motor power	kW	0.18 (230/50)	E (mm)	485	485
		0.22 (220/60)	H (mm)	417	599
Auger station motor power	kW	0.065 (230/50)	H1 (mm)	637	819
		0.08 (220/60)	L (mm)	253	283
Maximum noise level	db(A)	<80	W (mm)	B1 + B2	

CENTRAL HOPPER (3)											
	TC3	TC20	TB5	TB10	TB20	TB40	T2M	T3M	T5M	T10M	T20M
A (mm)	210	210	210	210	210	210	210	210	210	210	210
C (mm)	262	450	277	419	549	776	216	308	353	419	559
D (mm)	220	220	220	220	220	220	220	220	220	220	220
H2 (mm)	472	660	487	629	759	986	426	518	563	629	769
H3 (mm)	692	880	707	849	979	1206	646	738	783	849	989
M (mm)	ø238	353	ø309	ø309	ø309	ø309	ø193	ø300	ø300	ø373	ø373